

Larp S.R.L.

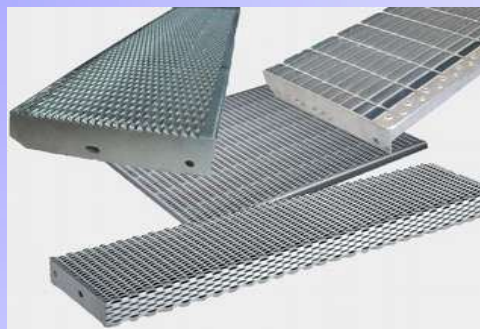
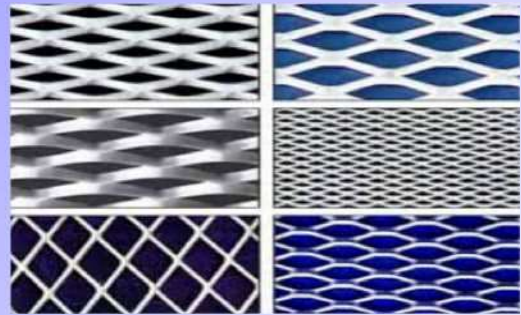
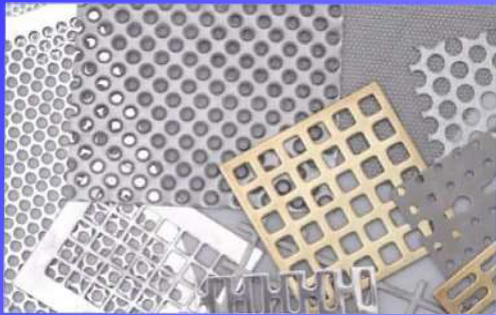

LARP Srl Unipersonale
Via Provinciale sp 28, n.2/b - 22070 Senna Comasco (CO)
Tel / Fax 031-710761 email: larp.senna@gmail.com

PRODOTTI IN ALLUMINIO

- / PROFILI H58
- / PIOLI
- / PROFILI AGE SPECIALI
- / PROFILO AGP SPECIALE

/ ESEMPI DI APPLICAZIONE

Mod. PROFILO AGE



Mod. PROFILO AGE



Mod. PROFILO AGE



Mod. PROFILO AGE



Mod. PROFILO AXF



Mod. PROFILO AGP



/ PROFILI H58 SENZA FORI ASOLE ALI

Mod. PROFILO AXB BUGNATO CIECO

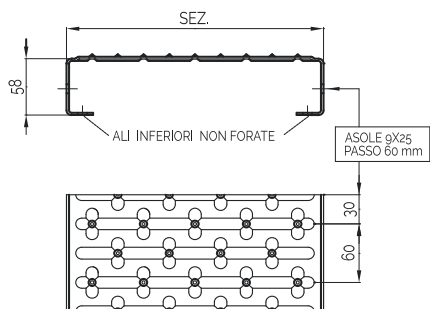

Spessore	mm	2,5
Passo di taglio	mm	60
Lunghezza Max	mm	6000

sez.	codice	peso Kg/m
200	3BAXB200LG	2,320
250	3BAXB250LG	2,650
300	3BAXB300LG	2,980

Mod. GRADINO AGXB BUGNATO CIECO

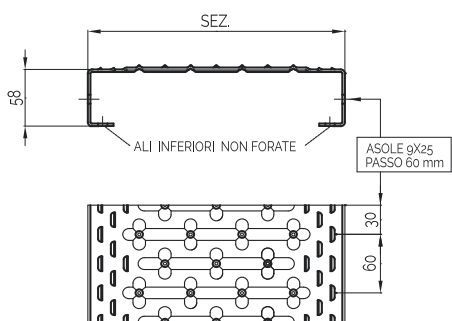

Spessore	mm	2,5
Passo di taglio	mm	60
Lunghezza Max	mm	6000

sez.	codice	peso Kg/m
250	3CAAB250LG	2,650
300	3CAAB300LG	2,980

Mod. PROFILO AXF BUGNATO CON FORI DA Ø 8

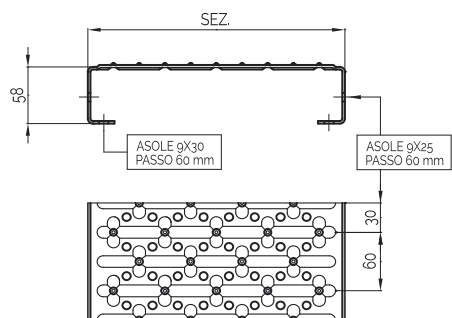

Spessore	mm	2,5
Passo di taglio	mm	60
Lunghezza Max	mm	6000

sez.	codice	peso Kg/m
200	3BAXF200LG	2,290
250	3BAXF250LG	2,618
300	3BAXF300LG	2,940

Mod. GRADINO AGXF BUGNATO CON FORI Ø 8

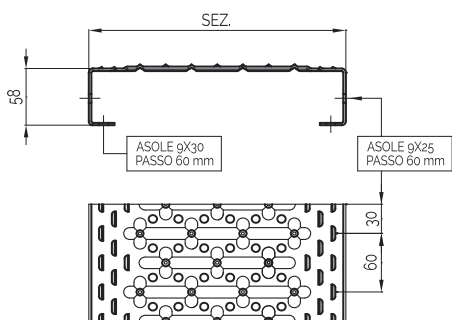

Spessore	mm	2,5
Passo di taglio	mm	60
Lunghezza Max	mm	6000

sez.	codice	peso Kg/m
250	3CAAF250LG	2,618
300	3CAAF300LG	2,940

Note: Non è possibile fornire profili con lunghezze diverse dai multipli del passo di taglio (es. 3600 OK, 3670 NO)

Mod. PROFILO AGE FORATO

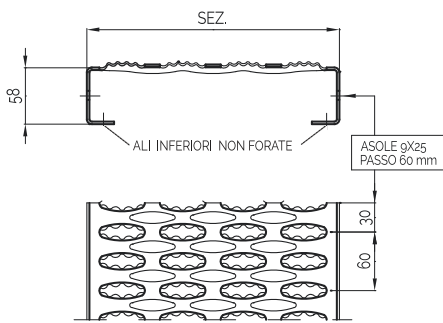

Spessore	mm	2,5
Passo di taglio	mm	60
Lunghezza Max	mm	6000

Note: Non è possibile fornire profili con lunghezze diverse dai multipli del passo di taglio (es. 3600 OK, 3670 NO)

sez.	codice	peso Kg/m
200	3AAGE200LG	1.920
250	3AAGE250LG	2.130
300	3AAGE300LG	2.450
350	3AAGE350LG	2.650
400	3AAGE400LG	2.880
500	3AAGE500LG	3.340

Mod. GRADINO AGF CON FORI Ø 10

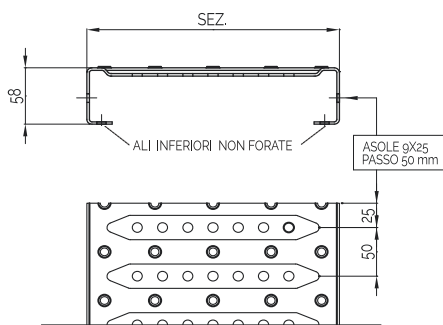

Spessore	mm	2,5
Passo di taglio	mm	50
Lunghezza Max	mm	6000

Note: Non è possibile fornire profili con lunghezze diverse dai multipli del passo di taglio (es. 3500 OK, 3530 NO)

sez.	codice	peso Kg/m
150	3CAGF150LG	1.920
250	3CAGF250LG	2.450
300	3CAGF300LG	2.800

/ PROFILO AGP SPECIALE

Mod. PROFILO AGP FORATO

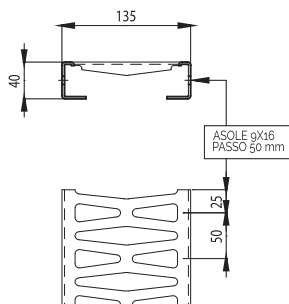

Spessore	mm	2,5
Passo di taglio	mm	50
Lunghezza Max	mm	5500

sez.	codice	peso Kg/m
135x40	3PAGP135LG	1.600

/ PIOLI

Mod. PIOLO 25x30

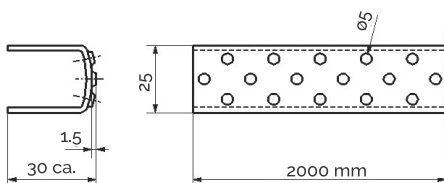

Spessore	mm	2,0
Passo di taglio	mm	/
Fornitura Verghe	mm	2000

sez.	codice	peso Kg/m
20 x 30	3LAGR025HG	0,410

PROFILI AGE SPECIALI

Mod. AGE C3 FORATO

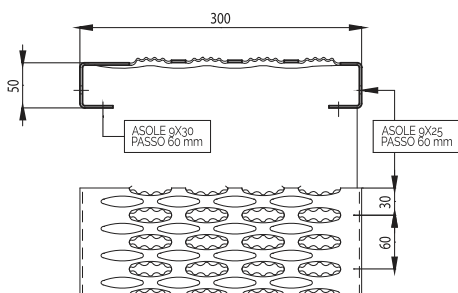

Spessore	mm	2.5
Passo di taglio	mm	60
Lunghezza Max	mm	5460

sez.	codice	peso
300	3NAGE300LG	2.430

Mod. AGE C8 FORATO

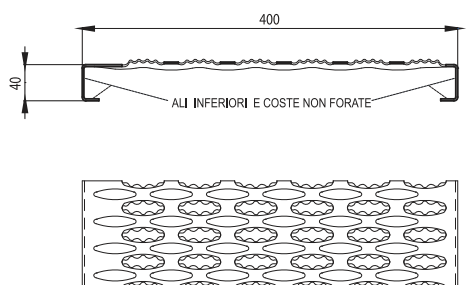

Spessore	mm	2.5
Passo di taglio	mm	60
Lunghezza Max	mm	5460

sez.	codice	peso
400	3PAGE400LG	2.770

Mod. AGE P1 FORATO

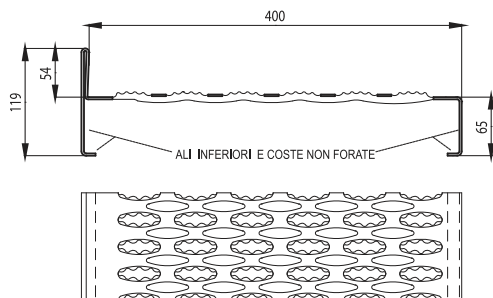

Spessore	mm	2.5
Passo di taglio	mm	60
Lunghezza Max	mm	4020

sez.	codice	peso
405	3LAPV045LG	3.750

Mod. AGE P2 FORATO

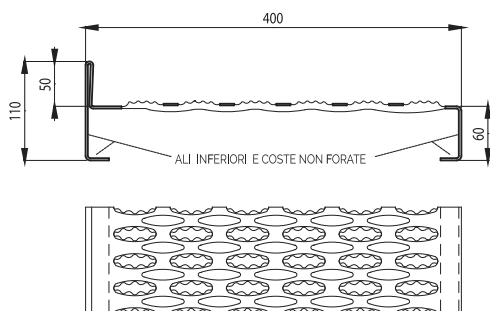

Spessore	mm	2.5
Passo di taglio	mm	60
Lunghezza Max	mm	4020

sez.	codice	peso
400	3LAPV411LG	3.750

/ PROFILI AGE SPECIALI

Mod. AGE P3 FORATO

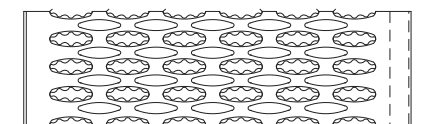
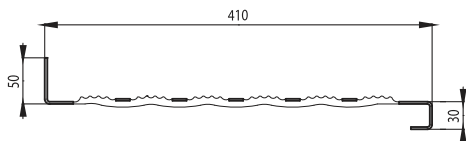

Spessore	mm	2.5
Passo di taglio	mm	60
Lunghezza Max	mm	4020

sez.	codice	peso
410	3LAPV041LG	2.840

Mod. AGE U2 FORATO

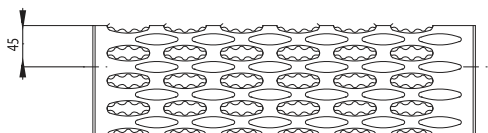
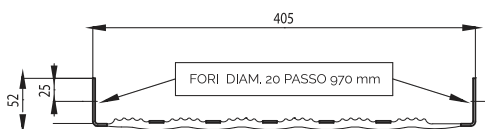

Spessore	mm	2.5
Passo di taglio	mm	60
Lunghezza Max	mm	5460

sez.	codice	peso
405	3LAPV405LG	2.650

Mod. AGE U3 FORATO

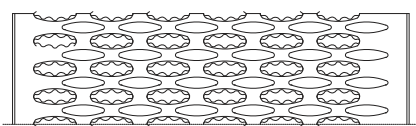
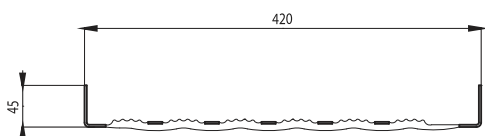

Spessore	mm	2.5
Passo di taglio	mm	60
Lunghezza Max	mm	5460

sez.	codice	peso
420	3LAPV420LG	2.650

Mod. AGE U4 FORATO

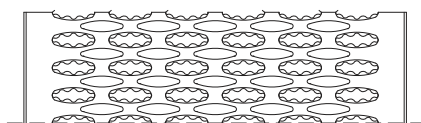
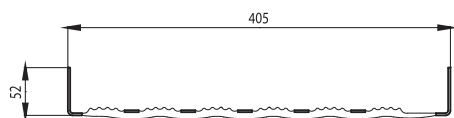

Spessore	mm	2.5
Passo di taglio	mm	60
Lunghezza Max	mm	5460

sez.	codice	peso
405	3LAPV040LG	2.750